

This article originally appeared in an Active Interest Media Company magazine or special interest publication.

Woodsmith®

CUISINE®
AT HOME

Garden Gate®

ShopNotes®

my home™
my style

workbench®



ACTIVE INTEREST MEDIA

All content in this document © Cruz Bay Publishing an Active Interest Media Company.
All rights reserved.

Simple & Fast Rabbeted Drawers

It takes only one setup on the table saw to cut every joint you need to make a solid drawer. Without a doubt, this is as easy as it gets.

Along the road to comfortably referring to yourself as a “woodworker,” there are a few important milestones you must reach. One of these is building your first drawer. For some reason, this project causes more antacid-popping than almost any other project.

A drawer is just a box. The tricky part is that the box must fit accurately into a hole and move smoothly. There are three steps to a successful drawer: precise measuring, accurate joining and careful fitting. This article shows you the tricks we use to successfully complete all three steps.

Measuring Like a Pro

Let’s say you’re building an end table with a drawer. Knowing the size of the drawer’s hole is the first critical piece of information. Seeing how that space is made and understanding how the drawer will “run” in the table is the next step. In traditional case construction, the drawer is just slightly smaller than its hole (which is the technique we’re showing here). In modern cabinets, the drawer is considerably smaller than its hole to make room for mechanical slides or glides.

In our traditional case, the drawer hole must be clear of obstructions or corners that the drawer can hang up on. For that reason, the sides of the drawer are traditionally kept in check by “drawer guides,” which are simply pieces of wood inside the carcass that are parallel to the sides of the drawer. Essentially, the guides create a smooth sleeve for the drawer to run in and out of.

With the guides in place, you’re ready to measure the opening for the drawer. You want to build a drawer that fits the largest part of its opening.

First measure the height of the drawer opening at the left side, right side and in the middle to make sure your case is square. The drawer for the “Simple Shaker End Table” on page 16 is an



PHOTO BY AL FARRISH

“inset drawer,” which means the drawer front doesn’t have a lip that covers the gap between the drawer and case. (Drawers with a lip are called “overlay” drawers, by the way.) Because this is an inset drawer, you should end up with a small gap all the way around the drawer front, called the “reveal.” The reveal must be equal on all four sides of the drawer opening at the top and bottom. Finally, measure the depth of the drawer space.

Now comes a tricky decision: Do you build

the drawer to fit the space exactly and then trim it down with a hand plane to allow for proper movement? Or do you trust yourself to build the drawer so that there is exactly $\frac{1}{16}$ " of space between the drawer and its guides?

We like to err on the side of caution. Build your drawer to fit the opening exactly and trim it to fit. If your drawer opening happens to be out of square, trimming the drawer is the easiest way to compensate. So build to fill the space, then work down to a smooth operational size.

One Setup Cuts All the Joints

Now that you know the size of your drawer, you're ready to build it. Mill all your stock to size (see the cutting list on page 18 for the Shaker end table drawer), paying particular attention to its thickness. The thickness of the sides and bottom must be exactly $\frac{1}{2}$ " for this operation to work well.

We're going to build our drawer exactly the size of our opening, except for the depth. The drawer's depth will be $\frac{1}{2}$ " shy of the depth of the opening to allow us to fit the drawer flush with its opening, which we'll explain shortly.

The drawings on page 26 show how we build simple drawers using one setup on the table saw. You won't have to change the blade height or move the fence as you cut these three joints:

- The $\frac{1}{2}$ "-wide x $\frac{1}{4}$ "-deep rabbets that join the sides to the front and back.
- The $\frac{1}{4}$ " x $\frac{1}{4}$ " groove on the sides and front that holds the bottom in place.
- And the $\frac{1}{4}$ " x $\frac{1}{4}$ " rabbets on the bottom that allows it to slip neatly into the grooves.

It may not be the way you'll build all your drawers, but it's simple and nearly foolproof. The $\frac{1}{2}$ "-wide x $\frac{1}{4}$ "-deep rabbets at the corners – when reinforced with brads – make the drawer resist racking and tension. While this can't compare to a stout dovetailed drawer, it's more than adequate for most furniture applications.

To make the drawer a one-setup operation, you'll need a dado stack. Dado stacks traditionally have two 6"- or 8"-diameter saw blades that cut a $\frac{1}{8}$ " kerf – plus a variety of "chippers" that can be inserted between the two outside blades to adjust the width of the groove to be cut. For our

"Yes, risk-taking is inherently failure-prone. Otherwise, it would be called sure-thing-taking."

— Tim McMahan (1949–)
international business speaker, author, photographer

drawer, we're going to use only the two $\frac{1}{8}$ " outside blades to achieve a $\frac{1}{4}$ " groove.

(Note: If you don't have a dado stack, you can use an $\frac{1}{8}$ "-kerf rip blade. You'll have to make a few extra passes over the blade, and you will need to move the fence, but only once.)

Now install a new zero-clearance throat insert to be used for this operation alone. (You can buy one from any tool supplier or make one using your saw's stock insert as a template; your saw's manual should show you how.) Without this new insert, rabbeting the bottom using your stock insert can be dangerous, especially with a left-tilt saw. The opening will be too big and your work could tip into the blades.

With the two dado blades installed on your saw's arbor, raise them so they are exactly $\frac{1}{4}$ " above the new insert. Set your saw's rip fence so it is exactly $\frac{1}{4}$ " away from the dado stack. Confirm your setup with some test cuts and dial calipers.

Use the drawings to walk through the simple rabbeting steps for the front and back, and the grooves for the bottom.

If you use a $\frac{1}{4}$ "-thick plywood bottom instead of solid wood, you're done at the saw. If you're using a $\frac{1}{2}$ "-thick hardwood bottom, you need to cut the rabbet on its edges so it slides in place.

We've shown two different ways to make a bottom here. In the drawings, we show a bottom that actually extends past the back. The back is cut $\frac{1}{2}$ " narrower than the front. This has several advantages: You can remove the drawer bottom for finishing and easily replace it if it ever gets damaged. It's necessary to build drawers this way when they are deeper than 12" to allow the solid-wood bottom to expand and contract without binding or busting the drawer.

Second, in the photos we've shown a bottom that is completely captured by the groove on the sides, front and bottom. In small drawers such as this one, wood expansion isn't a major concern and this method allows all the drawer pieces to be the same width.

Fine-tuning and Assembly

Before assembling the drawer, dry-fit the parts to ensure everything will go together easily. The rabbets should fit easily, but the bottom needs to slide into its groove without forcing, and you need to make sure the bottom isn't keeping the corner rabbet joints from closing tightly.

If the bottom is too tight you have a few options. You can head back to the saw and move the fence a little closer ($\frac{1}{32}$ ", or at most $\frac{1}{16}$ ") to the dado stack and rerun the four edges to thin the rabbet. A couple of passes with a bullnose or shoulder plane will also thin down the rabbet quickly. If the bottom is holding the corner joints open, raise the height of the dado stack ($\frac{1}{16}$ " is fine) and, re-run the edges of the bottom. Then keep checking your fit and adjusting until you're ready to assemble.

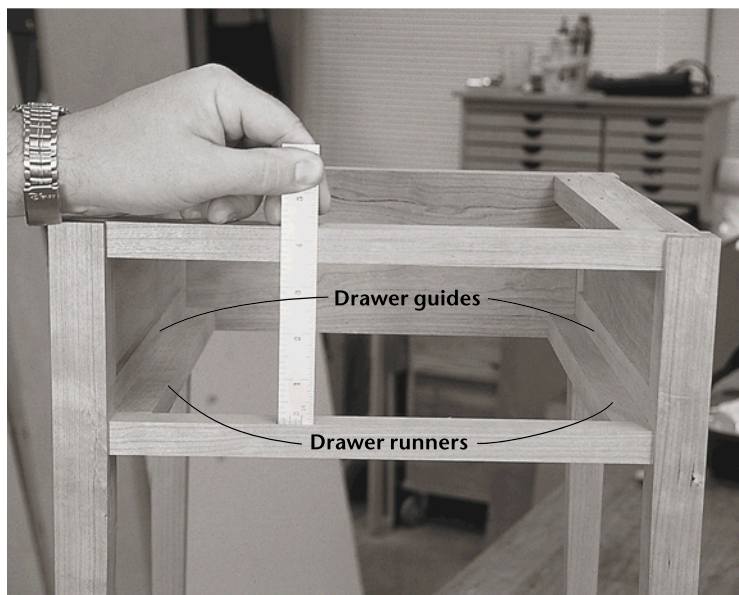

Here I'm measuring the height of the drawer opening near the center. You should also measure the height at both ends of the opening. The width also needs to be measured at top and bottom. Also shown in the photo are the drawer guides and runners in a typical case.

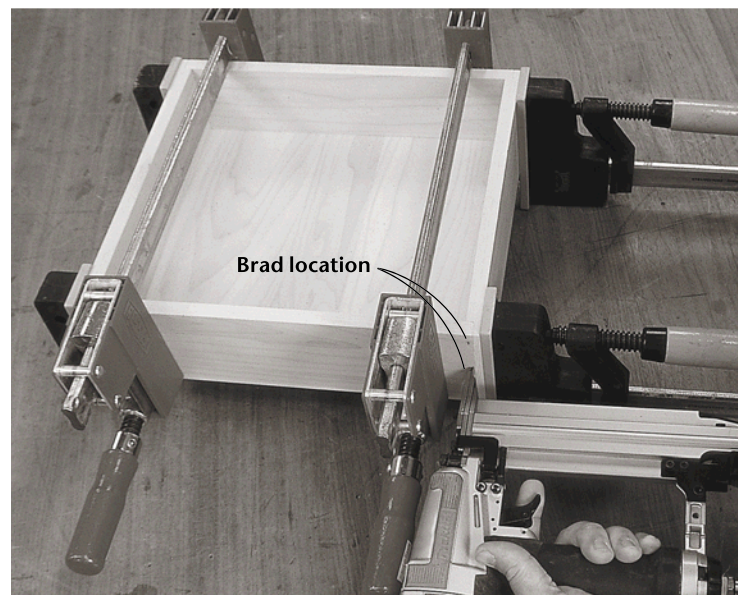

When building a drawer with a captured bottom, clamps are placed to apply pressure in both directions with the bottom in place. Note that the clamps are placed just behind the rabbet to apply as much direct pressure to the joint (without interfering with it) as possible. Brads add strength.

Build a Drawer with One Saw Setup

1

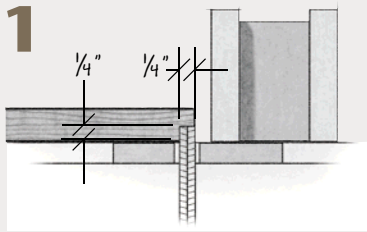

Set your $\frac{1}{4}$ "-wide dado stack at $\frac{1}{4}$ " high and $\frac{1}{4}$ " away from the fence. All of the crosscuts are made using the miter gauge to support the work. The first cut trims $\frac{1}{4}$ " off the end of the piece. Make this same cut on both ends of the front and back.

2

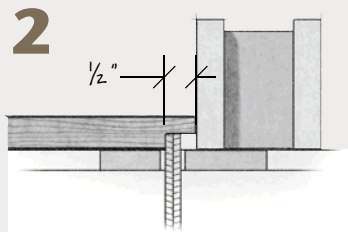

Make the second cut with the end of the piece pressed tight against the fence, which will create the full $\frac{1}{2}$ " width of the rabbet. Repeat this cut on both ends of the front and back.

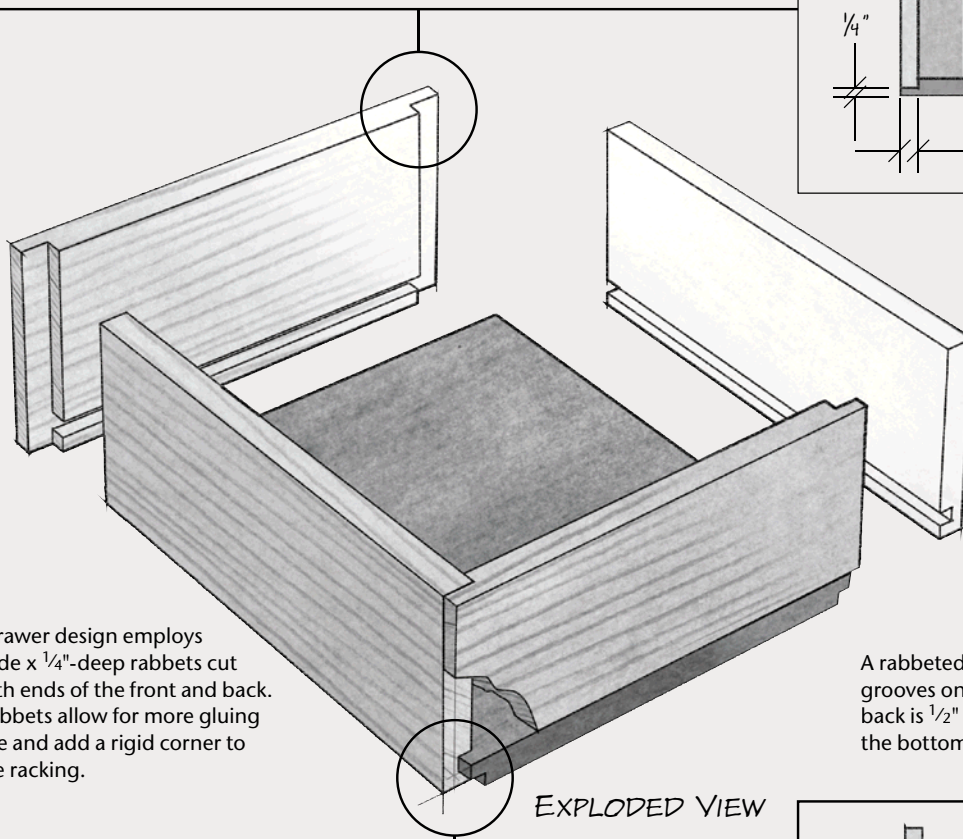
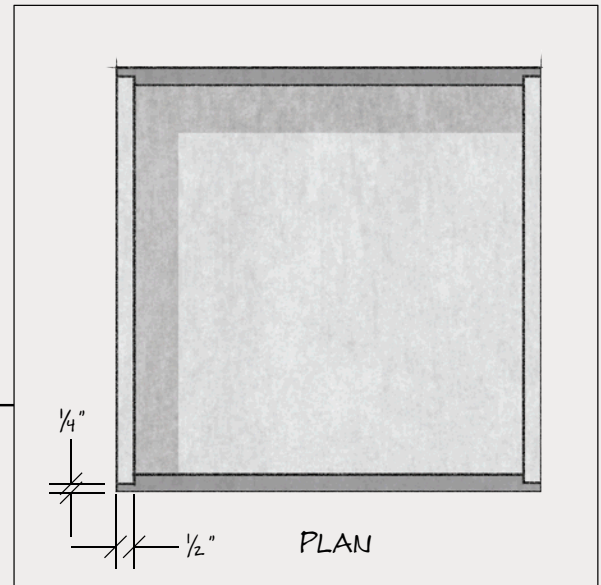

This drawer design employs $\frac{1}{2}$ "-wide x $\frac{1}{4}$ "-deep rabbets cut on both ends of the front and back. The rabbets allow for more gluing surface and add a rigid corner to reduce racking.

A rabbeted bottom fits into the $\frac{1}{4}$ " x $\frac{1}{4}$ " grooves on the sides and front. Note that the back is $\frac{1}{2}$ " narrower than the front to allow the bottom to slip in place under the back.

3

Keep your saw at the same setting to cut the $\frac{1}{4}$ " x $\frac{1}{4}$ " groove in the sides and front that holds the bottom in place. One pass is enough.

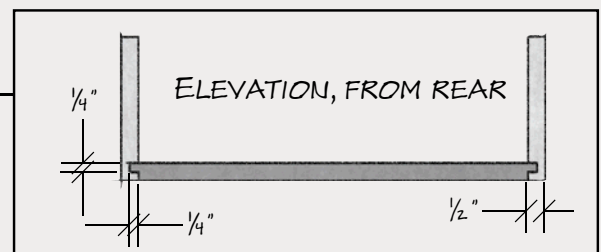
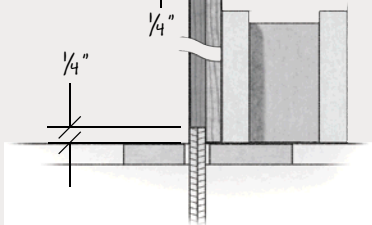
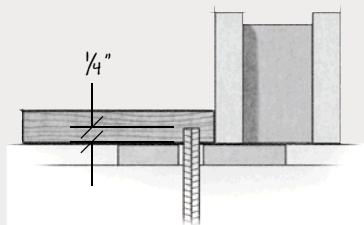

4

Finally, cutting a rabbet will allow the bottom to fit into the grooves. Make this cut with the bottom on edge as shown at left. This operation is dangerous without a zero-clearance insert in your table saw. Featherboards help keep the bottom tight against the fence during the cut.

Use glue and $\frac{5}{8}$ " brads to attach the sides to the front and back. Apply glue to the rabbets at the corners. If you're using a solid-wood bottom, don't place glue in the grooves. The bottom should be allowed to expand and contract (unless you're using plywood).

Slip your bottom into the groove and clamp the drawer. Place your clamps as shown in the photo on page 25. If you're adding brads to the joints, drive them through the sides into the rabbets in the front and back.

Fitting the Drawer in its Space

When the glue is dry, take the drawer out of the clamps and try to fit it in its opening. It probably won't fit. This is OK. The first step in getting it to fit is to take your block plane and remove material from the top edge of the sides, front and back, checking the fit as you go. You can easily gauge your progress by first marking a $\frac{1}{16}$ " line around the outside of the drawer. As you plane, use this line as a reference.

Check the fit of the drawer at the top and bottom by inserting one corner of the drawer in the opening so you don't have to worry about the side-to-side fit. When the drawer fits at the top and bottom, check the side-to-side fit.

Removing material from the sides can be done with a plane or a power sander. If you're planing, remember to work in from both the front and back to avoid tear-out on the end grain that shows on this surface. Remove material slowly and work both sides evenly. It shouldn't take much to get the drawer to slip into place.

You may notice at this point that the reveal around the drawer looks OK at the top and the sides, but the bottom is a tight fit. Here's a little trick: Take your block plane and lightly bevel the bottom front edge to give the appearance of a gap to match the top space. Continue to trim the front with your block plane until the reveal is consistent all around the drawer front.

If you're having trouble planing the end grain on the sides of the front, here's another little tip: Wet the end grain with some mineral spirits. This will make it easier to slice.

Now it's time to fit the depth. Because we made the drawer $\frac{1}{2}$ " shorter than its opening, it will slip in past the front edge of the table. Slide the drawer all the way in, and measure how far in it went. Then predrill and drive two #8 x 1"-long round-head screws (one on either side) in the drawer back. By adjusting the depth of the screws, you can fit the drawer front flush to the table.

With these basic skills in place, you can now use different material thicknesses. And as you become more comfortable with your skills, you can try a new drawer joint on occasion. But you'll always be able to make a simple one-setup drawer that fits perfectly with these rabbets. **WM**

— David Thiel



The first step in fitting the drawer is to trim the height. A simple block plane can be used to take off a little bit at a time until the fit is perfect.



Next, a larger jack plane removes material from both sides until the drawer slides in smoothly.

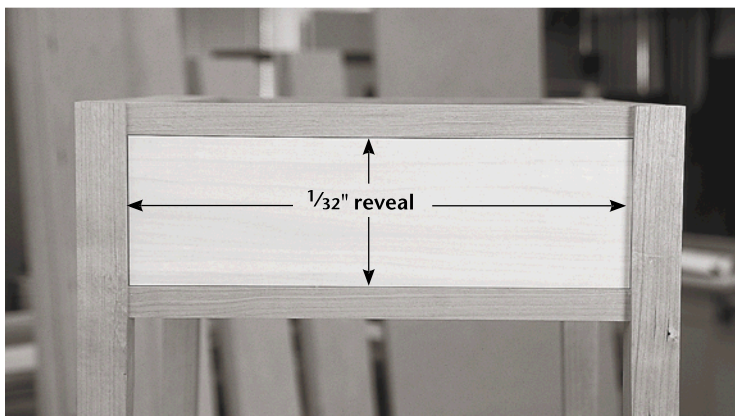

With the drawer in place, you can see the reveal at both sides, on top and on bottom. By beveling the lower edge of the drawer front with a block plane, the spacing appears to match on all four sides.

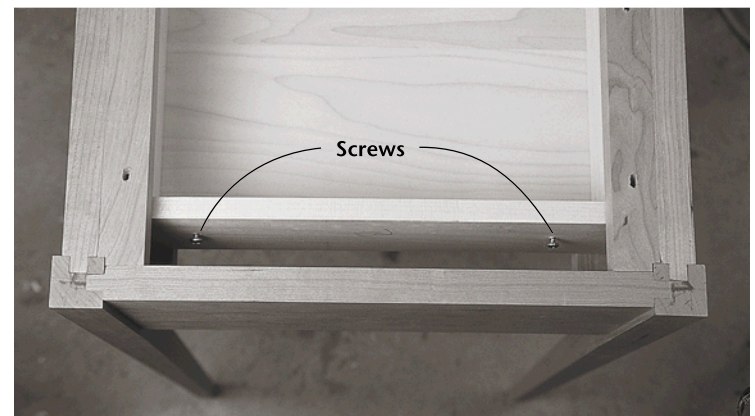

Another trick to fitting a drawer is to use screws in the back to help adjust the depth. The two screws can be adjusted in and out to fit the drawer front flush in the opening.